

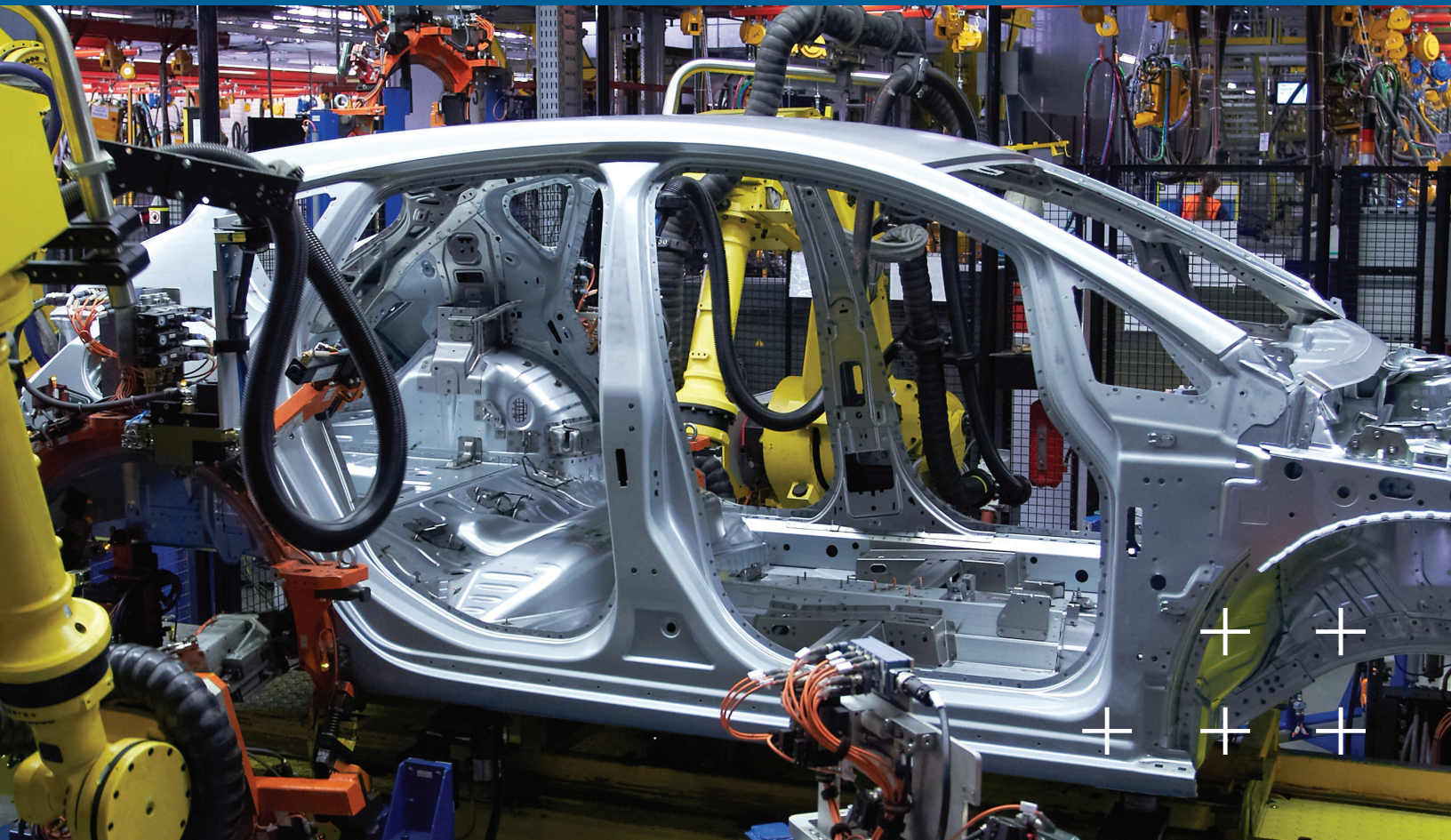

Solving supply chain challenges for volume production and spare parts.

The additive manufacturing solutions guide for automotive and transportation OEMs.





Opening doors for manufacturers.

The automotive and transportation industries are constantly evolving and the need for safer, high-performing parts only continues to increase. In this application solutions guide, you will learn about how additive manufacturing can help you overcome challenges commonly faced by automotive and transportation vehicle manufacturers as well as provide you with insight on specific solutions to help optimize your production lines.

This guide will also highlight the lead time and cost reduction that Stratasys® additive manufacturing solutions can provide for the automotive industry. For example, costs are up to 78% less than injection molding and lead times can be reduced from 12–20 weeks down to a few days before beginning production.



Cup holder

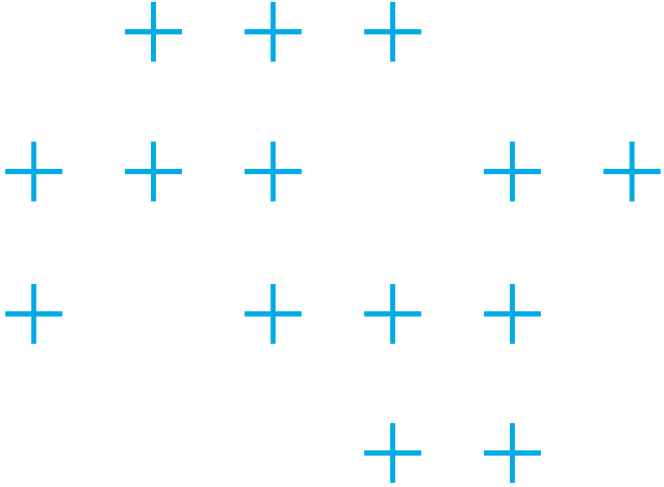

Front grille



78%



A versatile solution for OEMs.

Traditional manufacturing methods like injection molding and machining have long been the industry standard. However, additive manufacturing offers unique advantages that help manufacturers navigate challenges, minimize costs, speed up production and stay competitive in an ever-evolving market. Without incurring incremental cost, manufacturers can provide custom parts and personalized options to their customers — differentiating themselves from their competitors.

Tackling supply chain constraints.

While traditional manufacturing methods do have their advantages, the work is typically outsourced — which may delay shipments by days or weeks. This increased dependency on people and lead times can affect delivery and may create potential labor issues. Additive manufacturing gives you the ability to produce parts straight from the factory floor, eliminating wait times on part delivery from outsourced vendors — helping manufacturers keep production on track and accelerate their time to market.



Fan

Differentiating aftermarket parts.

Customers may want to further tailor their vehicle by incorporating parts like personalized dashboards or special cup holders. To ensure quick differentiation between OEM and aftermarket parts, 3D printed parts can easily be marked with an identifier (e.g., barcode, personalized pattern or name) during the production process.

Minimizing impact from recalled parts.

Whenever a recall takes place, any surplus in storage can become a wasted cost. With additive manufacturing, you don't have to worry about wasted surplus parts since 3D design files are all digital and can be modified and printed on demand. Plus, the only thing that needs to be stored is the additive manufacturing material. Material is usually available for the OEM in higher quantities, meaning there is no need to store large amounts.

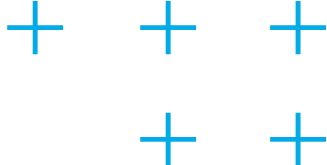

Enabling rapid prototyping and customization.

Traditional manufacturing methods often require long lead times, which makes it difficult to iterate part designs or develop custom parts while producing at a competitive pace. Using traditional methods to create custom parts is also impossible and not cost-effective for OEMs. On the other hand, additive manufacturing enables you to rapidly prototype various part designs and create fully custom parts in a matter of days.

Complex, high-volume parts. Accelerated.

Rapid prototyping isn't the only application additive manufacturing can handle. Automotive and transportation industries often require end-use parts with unique or complex geometries. With Stratasys solutions, you can produce high-volume, end-use parts with challenging geometric properties — such as moving parts, connectors, hinges, clips and snap fits — with speed, precision and repeatability.

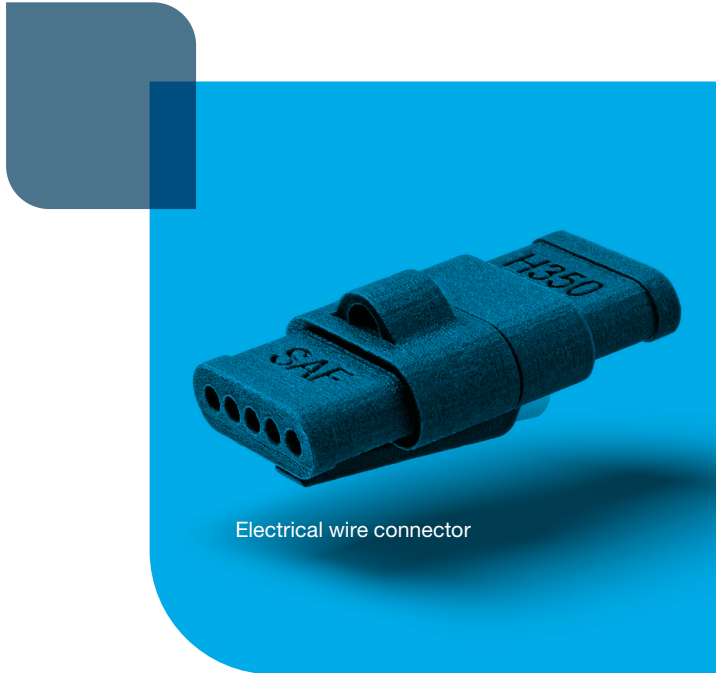

Electrical wire connector

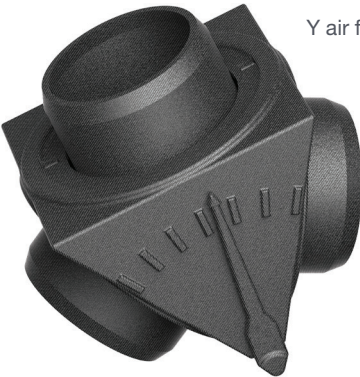

Y air flow split

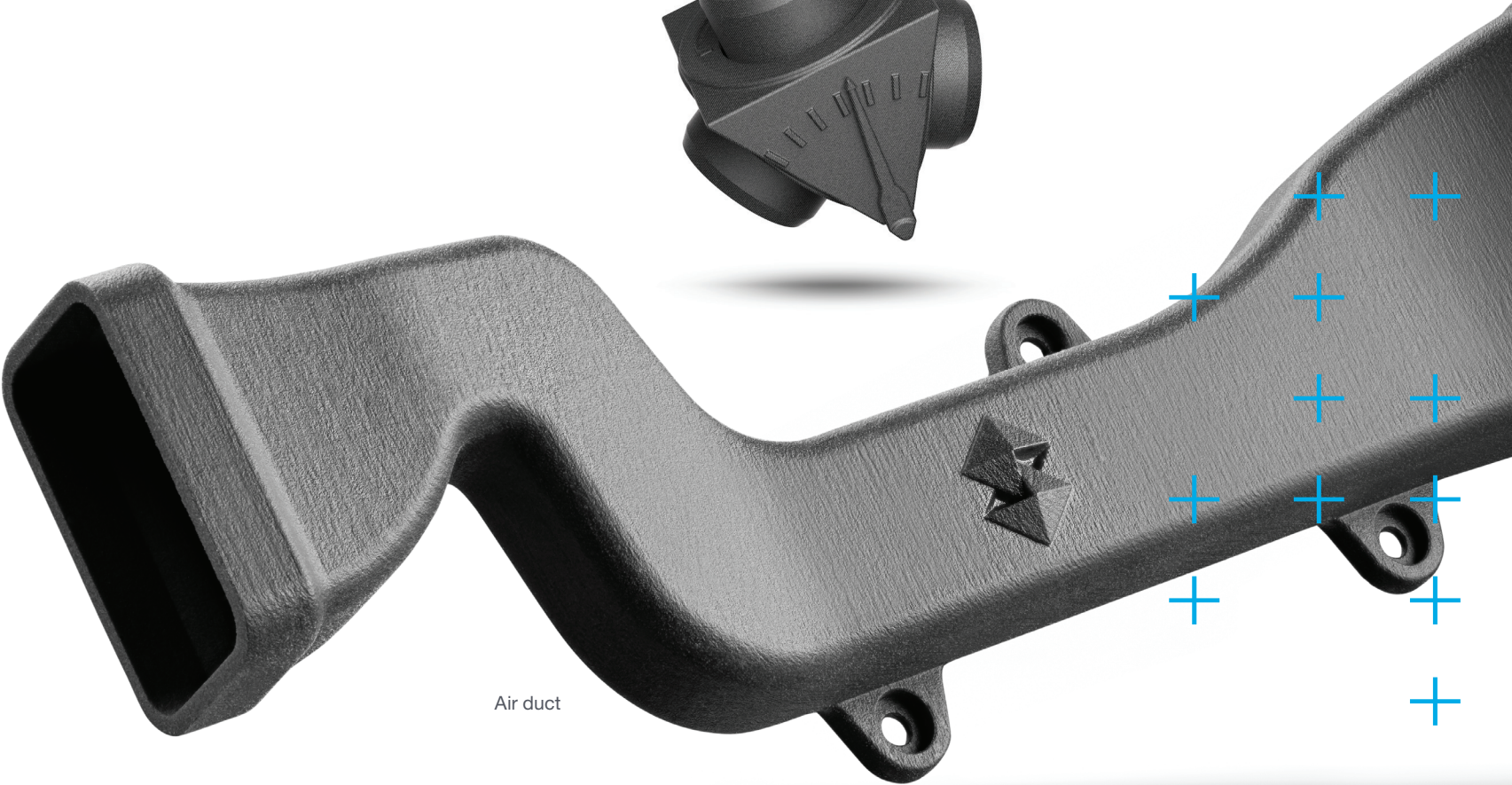

Air duct

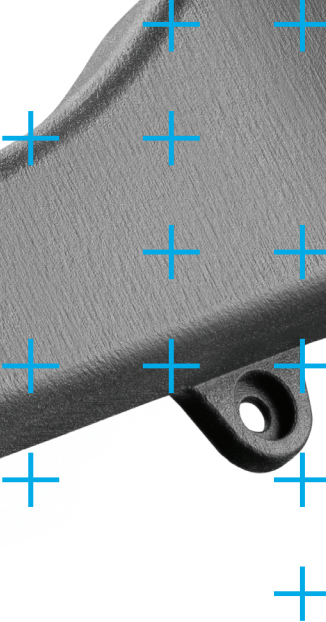

Parts that you control.

Built for high volume, the Stratasys H350™ 3D printer featuring SAF™ technology gives you control of your materials, workflow, production and costs while delivering accuracy and production-level throughput for end-use parts.

Control consistency.

The H350's unique thermal management and patented Big Wave™ powder deposition enable you to achieve uniform part consistency throughout your build and ensure reproducible part quality made to your exact specifications — even on fine feature details, flat areas and large parts. Plus, you get stable production configuration thanks to long-lasting industrial printheads.

Control your workflow.

Having the flexibility to tailor your own workflow empowers you to meet your customers' specifications. The H350 has no mandatory connection to any internet cloud or forced firmware updates. You can save and reuse print settings at any time as well as monitor and adjust settings to produce the part qualities your business needs. You can also reproduce precise, geometric measurements and mechanical properties to achieve part consistency.

Control your costs.

The H350 offers simple and predictable part cost estimation while helping you manage fewer consumables and produce consistent and accurate parts made up of 70% reused powder. Plus, you'll save on machine recertification and part costs with the help of the H350's long-lasting printheads and 12% nesting density.

Certify production.

Highly regulated industries like automotive require part- and material-specific certification. With the H350, you can certify the products and parameters for your customers, log build data and receive process traceability. It is also possible to reproduce OEM parts that are now obsolete or no longer available. You can also create spare parts on demand for discontinued vehicles — without recertification — helping you save on tooling costs while practicing a more sustainable manufacturing process. Additionally, producing parts with the H350 gives you the option to pursue additive manufacturing facility qualification, which is a growing demand.

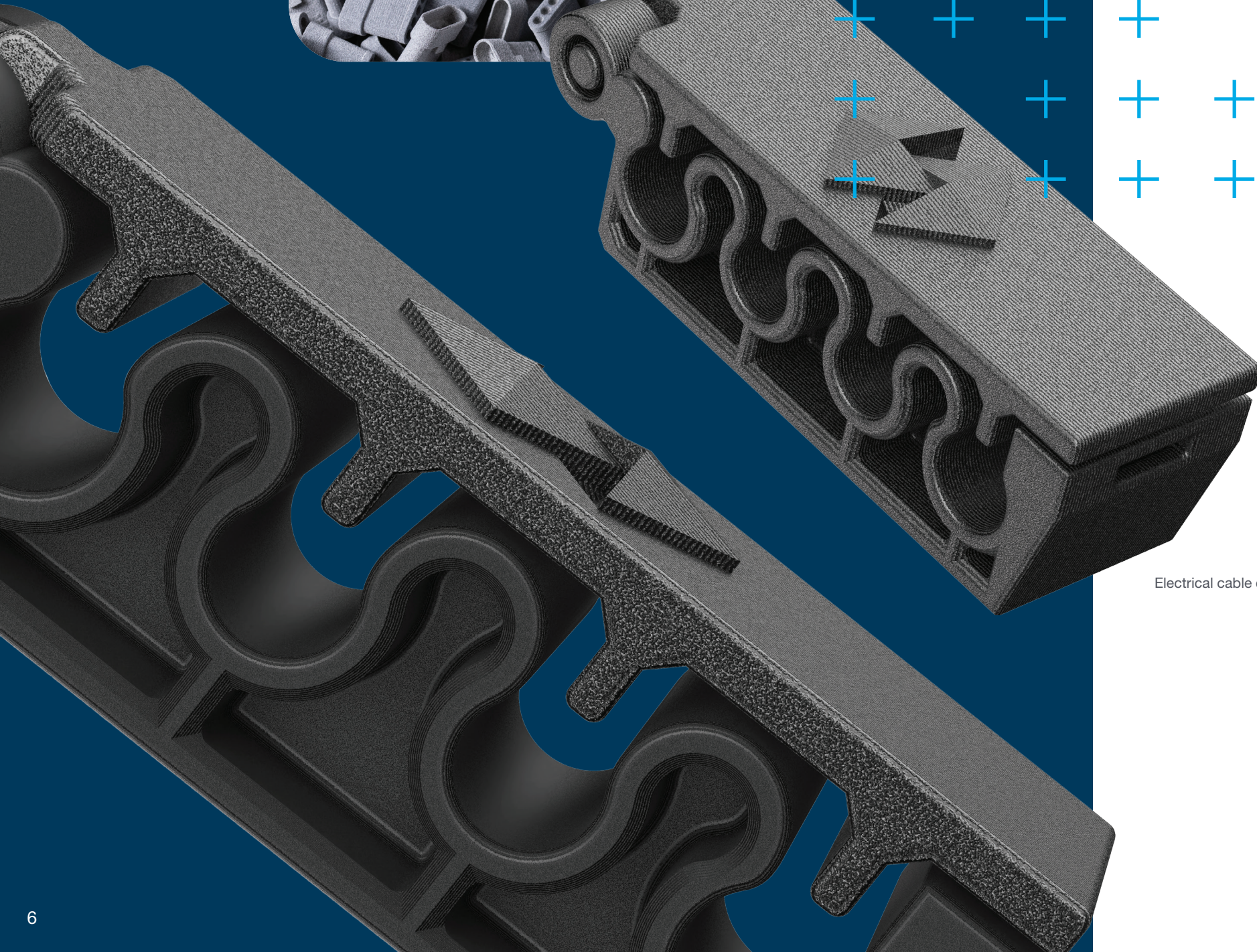

Electrical cable clips

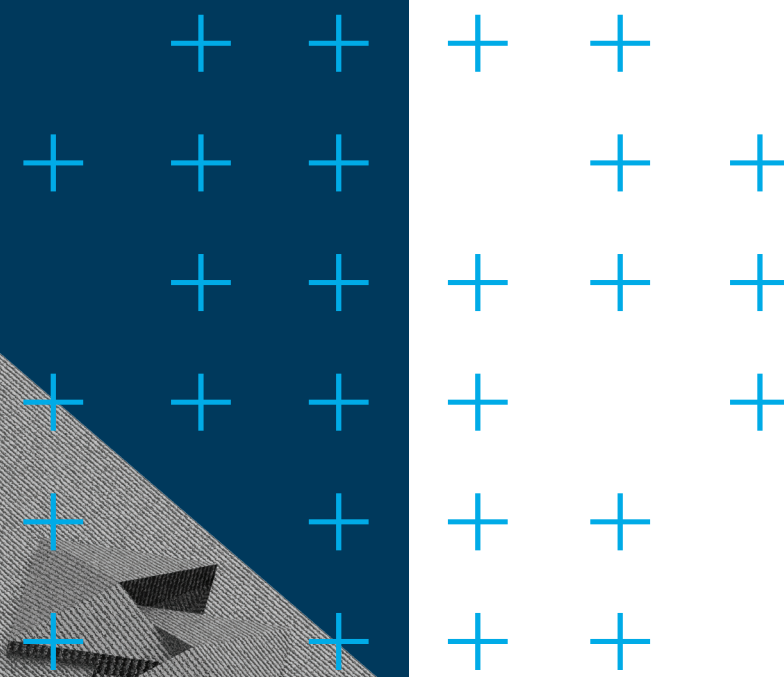

Explore industry possibilities.

The H350 3D printer can be used to produce a broad range of interior parts for various automotive and transportation applications as well as light and heavy commercial vehicles.



H350 3D printer

Print to your exact specifications.

The H350 3D printer powers the production of parts with complex geometries, fine detailing, thin or thick walls and smooth surface finishes. Flat parts, that are often difficult to execute, can also be produced with precision. Parts printed with the H350 are proven to be strong, durable, functional and highly accurate. Specific performance requirements like impact resistance can also be achieved.

Materials: High Yield PA11

Ideal for: serial production ranging from 1,000 – 20,000 parts and spare parts



Side mirror

Air duct

Y air flow split

Electrical cable clips

Electrical wire connector

Front grille

Front bumper sensor bracket

Under-hood applications may require high HDT [Heat Deflection Temperature] materials for production. In this case, PA11 polymer powder would be more suitable for prototyping.

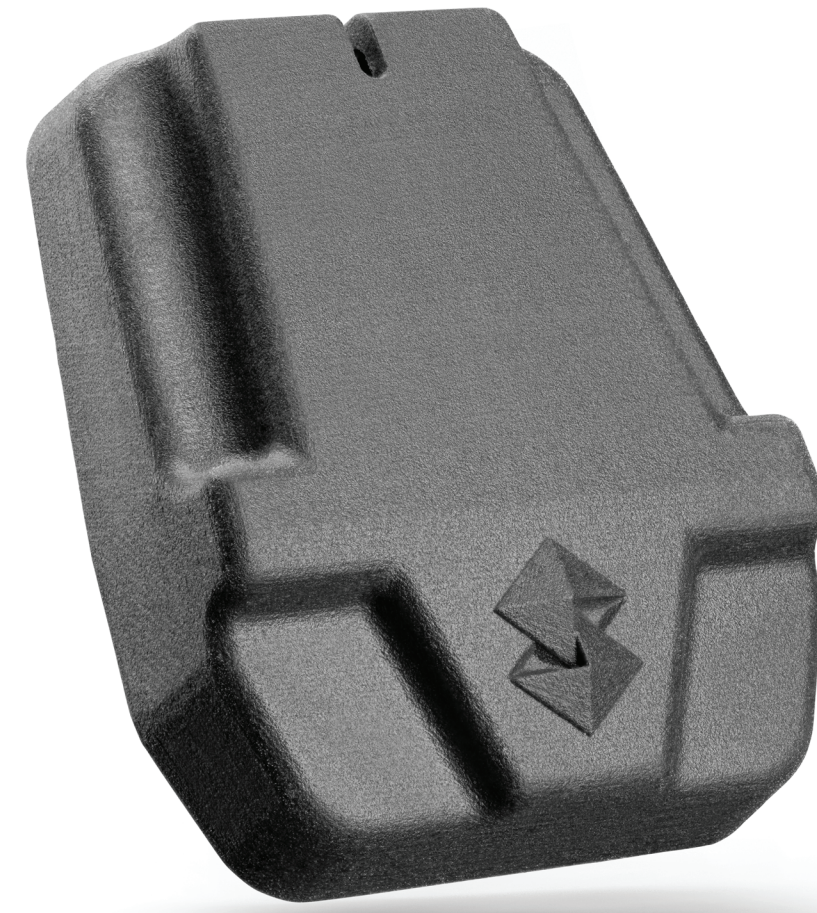
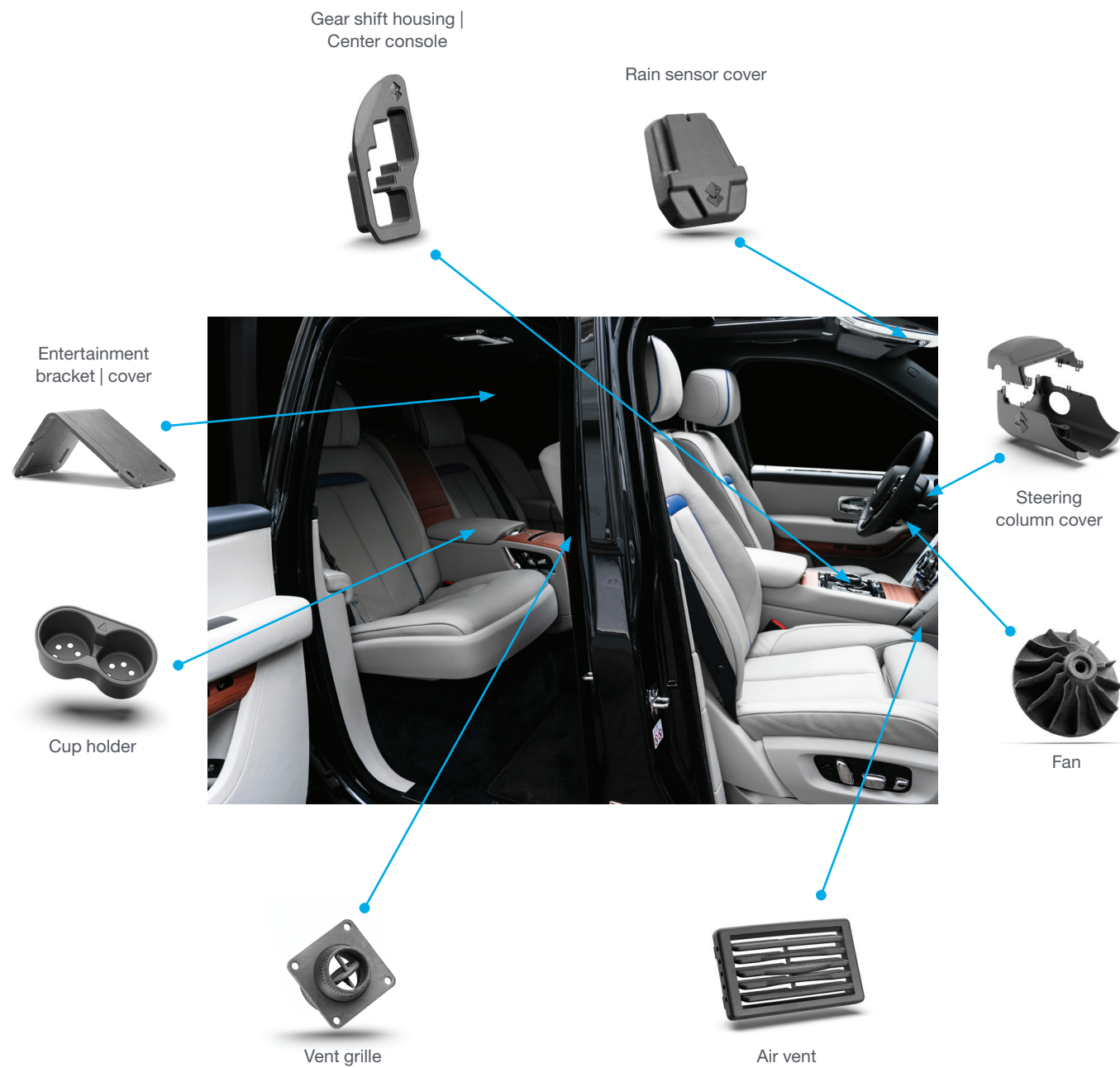

An example of a typical automotive part is a rain sensor cover.

Since the part will be visible, the exterior face must have a smooth and even finish. There are clips and location pins on the inside of the part to locate and mount it correctly into position. These clips and pins must be built accurately and repeatably, so they fit perfectly each time. As shown in Figure 1, 80 parts can fit in a single build.

The build in Figure 1 also had a total turnaround time of 13.5 hours. This is calculated from the start of the build until the build is removed the machine, which can then be prepared for the next build. Once removed, the build must be cooled before the parts are removed from the cake. This yields a low cost of \$7.13 per part, based on 1,000 parts. This is compared to \$11.44 per 1,000 parts with injection molding.

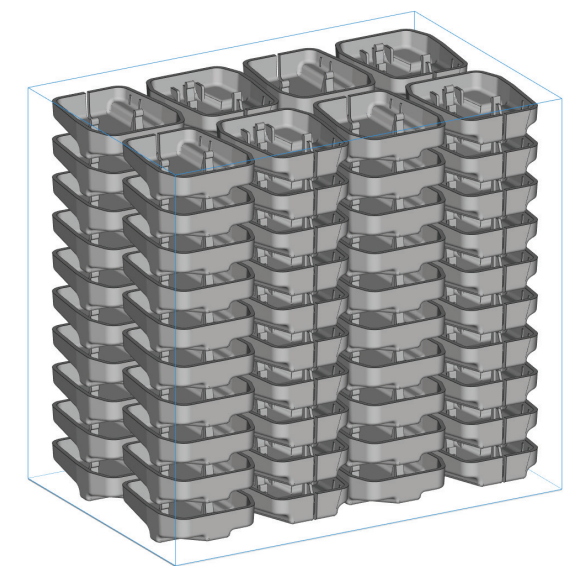

Figure 1

Overcome implementation barriers.

From consulting to on-demand parts, Stratasys offers a wide range of additive manufacturing services at every stage of the process. If you want to use more demanding additive manufacturing technologies but don't have the space or budget for it, Stratasys can provide a team of experts to support you at every stage of the product development and manufacturing process.

Ready to transform production?

Find a local reseller today at stratasys.com.

© 2022 Stratasys. All rights reserved. Stratasys, the Stratasys Signet logo, H350, SAF and Big Wave are trademarks or registered trademarks of Stratasys Inc. and/or its affiliates. The H350 printer is subject to a license from Loughborough University Enterprises Limited and Evonik IP GmbH under the following and/or related patents and patent applications and their family members: EP2739457, EP3539752, EP1648686, EP 1740367, EP1737646, EP1459871. Further details, including live and in-force status of family members, may be found at <https://worldwide.espacenet.com/patent/search/family/>. All other trademarks are the property of their respective owners, and Stratasys assumes no responsibility with regard to the selection, performance or use of these products. Product specifications subject to change without notice.SB_SAF_Transportation and Automotive_0122a

